

Research on arcade systems

Konami's Ping Pong PCB Analysis

A Ping Pong arcade PCB was analyzed in order to convert the system to modern FPGA-based electronics. The full schematics were extracted, annotated and sensible signal names were attached. The function of the custom chips was derived from the surrounding discrete logic and measurements were taken to check assumptions on them. A small custom firmware was written to check other aspects of custom chips. The CPU bus contention was measured and modeled.

Acknowledgments

This work was sponsored by JOTEGO's [patrons](#). The PCB was loaned by Twitter user @supercrow123. Special thanks to DJ Hardrich, Martin and atrac17 for their continuous support.

Board Overview

The board belong to the Konami series based on the 082, 083, 503 and other custom chips. Although it does not use all of them and the screen counters are exposed as discrete logic. Two DIP-28 footprints connect to two identical daughter boards with just three standard logic chips on them.



The graphics are only 2-bit per pixel and the color DAC uses 3 bits for red and green and only 2 bits for blue. Sound is generated by a single SN76489 chip. There is only one CPU, a Z80 and the CPU shares the RAM chip with the object table, which means that there will be bus contention when accessing it. All these features point to a low-budget project, particularly when compared to other such as Track & Field.



The PCB with the two 28-DIP daughter boards removed

CPU and Bus Contention

The critical signals are controlled in this way:

- Bus request: not exercised
- NMI: every 16 lines
- INT: once per frame, when entering V-blank
- WAIT: when the CPU tries to access the video memories but the hardware is reading them, the WAIT signal is asserted halting the CPU

The frequency is 3.07MHz, derived from a crystal clock at 18.43MHz, which is divided by three using two JK latches, and then by two by a D flip flop.

There is a watchdog and reset chip, the TA7900S, common to other Konami boards too. A jumper on the board allows to bypass the watchdog by closing it with solder.



Wait goes low if the GFX are driving the memories but the CPU also needs to access

CPU Bus Custom Chip

A custom chip at location D5 serves the following functions:

- External data bus line driver
- External bus selection line, derived from A15
- Arbiter between the CPU and the video hardware to divide access to RAM chips
- Write signal to bus devices

Graphic RAM is time-multiplexed at 1.5MHz between the CPU and the graphic chips.

System I/O

The board uses Konami's small edge connector (not JAMMA). There are three DIP switches, two of eight bits and a third one of 4 bits. However, the MSB of the third one is not connected to the data bus.

There are two test connectors to which the CPU can write. A couple of general signals (the GFX multiplexor select and V256) are also passed on through these connectors. The CPU cannot read from them.

Sound

A single SN76489 chip is used, unlike other systems of the same age that used several sound sources. There are no programmable filters or sound enable relays. The power amplifier used is the LA4460, common to other Konami games of the era. Data is written to the chip in two steps, first a byte is written to a latch and then a second write will make the SN chip read the latch.

Graphics

There are two graphic layers: the characters and the objects. There is no scroll layer. The objects are drawn on top the characters. The custom chip 503 produces a signal to distinguish blank object pixels. Based on this signal either the character pixel or the object pixel is chosen and passed to the video DAC.

There are three palette PROMs, one for characters, one for objects and a final one to drive the flash DAC. The bus connection from the object PROM output to the pixel multiplexer is reversed, probably by mistake: the MSB is connected to the LSB and so on.

The character layer is made of 2-bit pixels, which makes the reading circuitry simpler. Nonetheless, there are 6 bits to select different 4-color palettes so the amount of color in the screen doesn't seem as poor as one could expect from 2-bit pixels. There is no scroll and no global flip signal but the character can be flipped horizontally and vertically.

The object layer can draw a total of 24 objects, each object data is made of four bytes. The object table occupies the first 24x4 byte locations of the RAM. However, due to what seems to be another mistake, one of the bytes is kept during the time equivalent to 16 pixels stored in a latch. This means that the rendering hardware gets that byte from the previous object in the table and not the current one. The software works around this problem by writing that byte offset by one in memory, but the first object in the table cannot be recovered and is lost due to this problem.

The object table is read in the following order:

1. objects from 8 to 15
2. objects from 0 to 7
3. finally, from 16 to 23

There are two custom chips for object drawing:

- Konami's 503 is used to identify when an object must be drawn

- Konami's 502 controls the double line buffer

Objects drawn first will hide objects drawn later due to the way the 502 logic works. The 503 also stores the vertical and horizontal flip values and applies it to the lines driving the object graphics ROM.

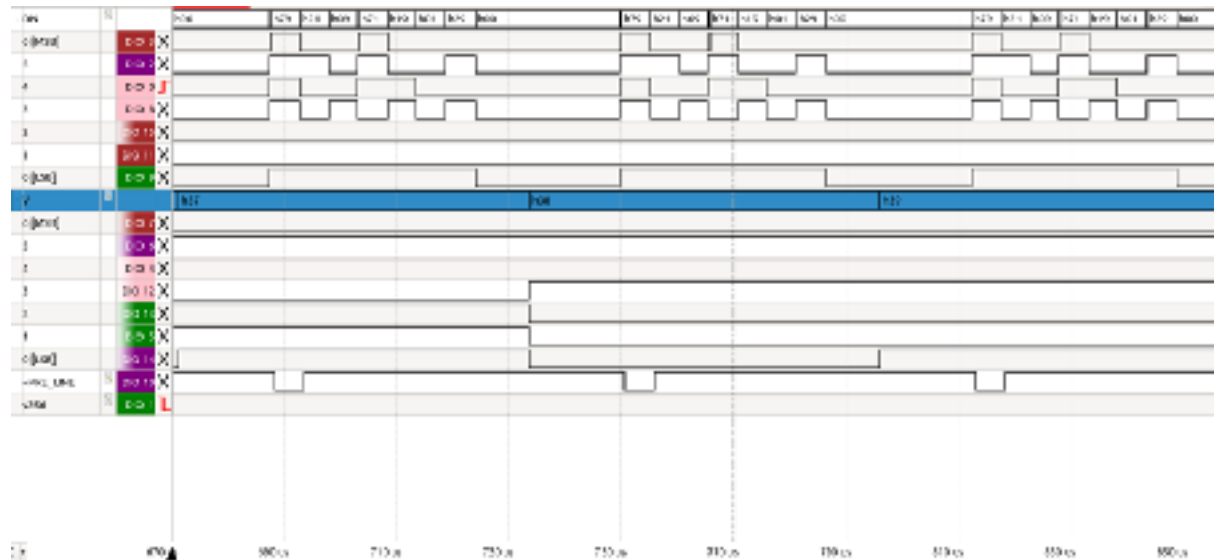

Custom chip 503 capture. ~PRE_LINE indicates an active object transfer

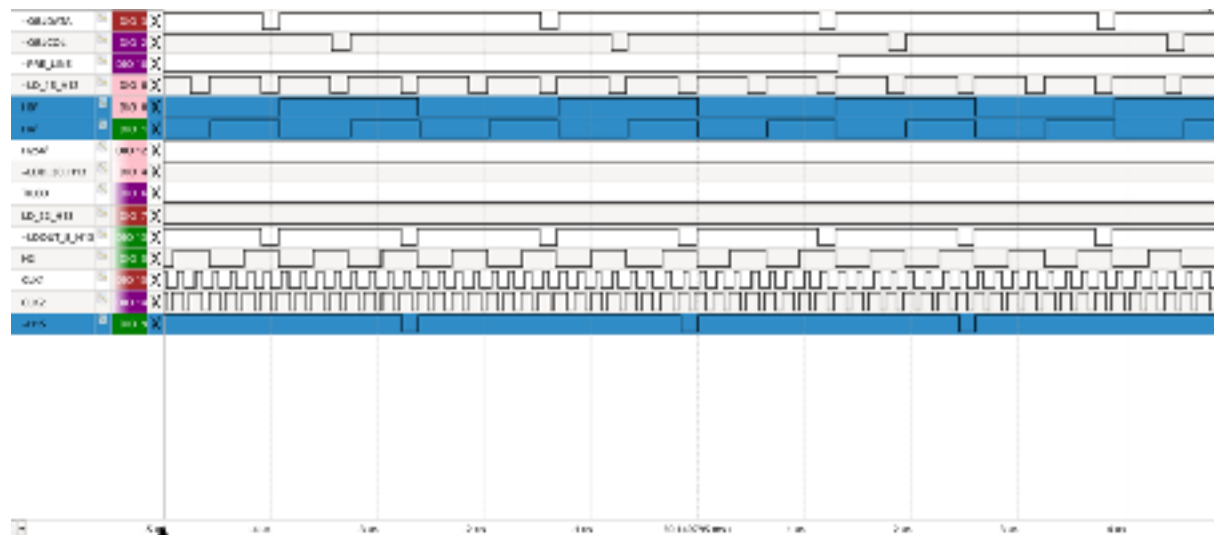

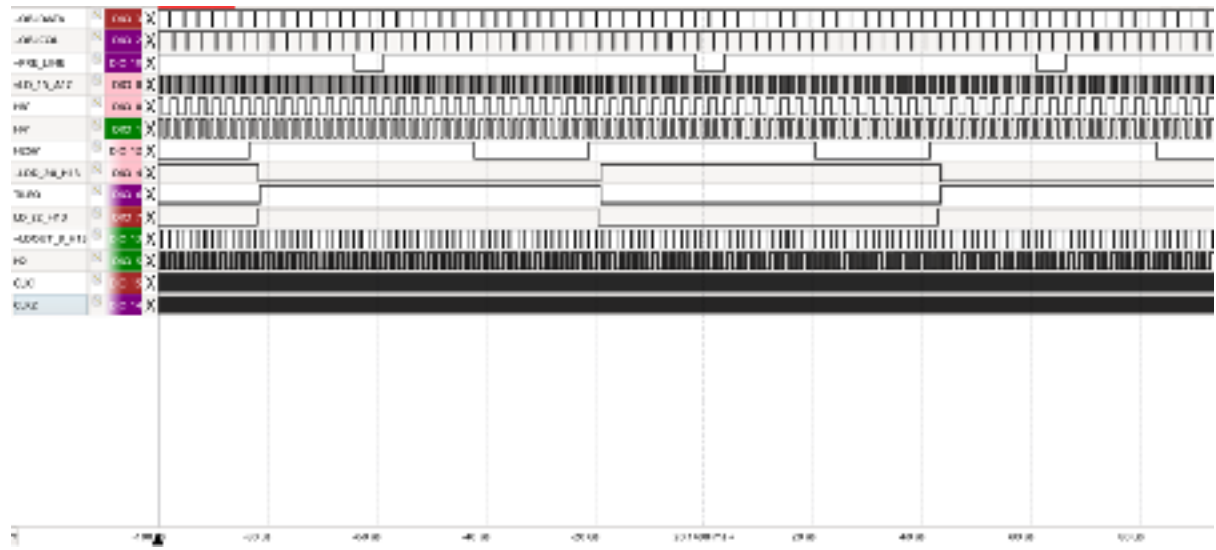

Clock signals controlling the object engine. ~H15 is the wrong one mentioned

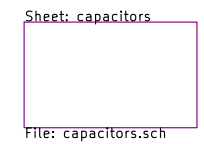
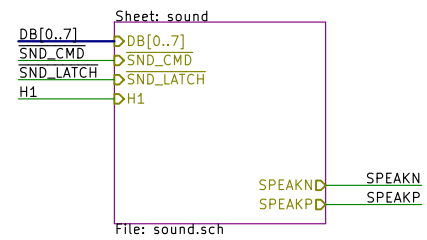
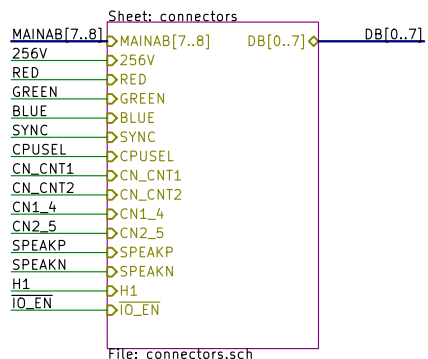
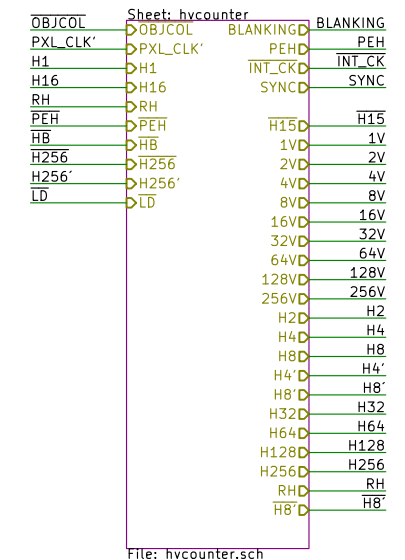
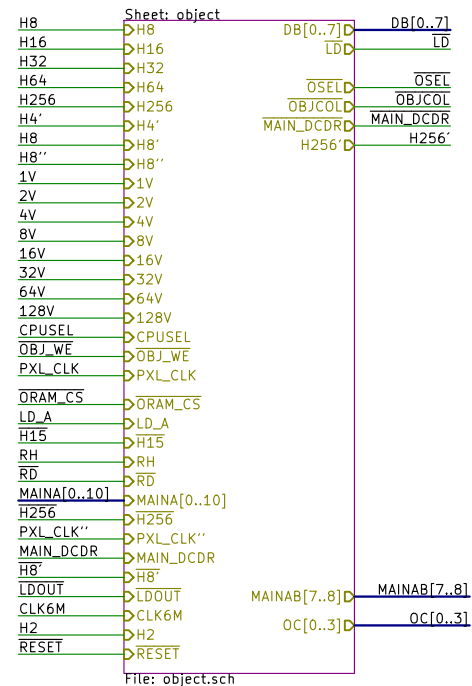
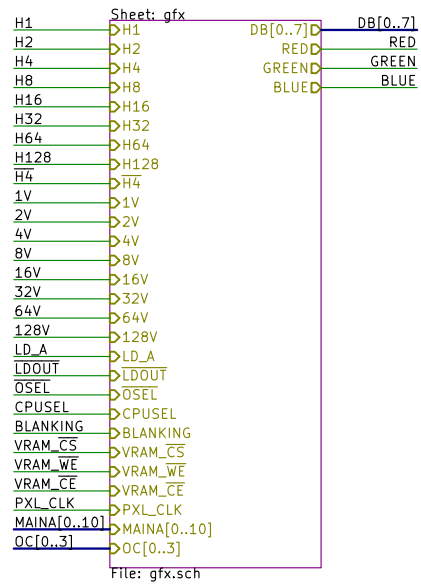
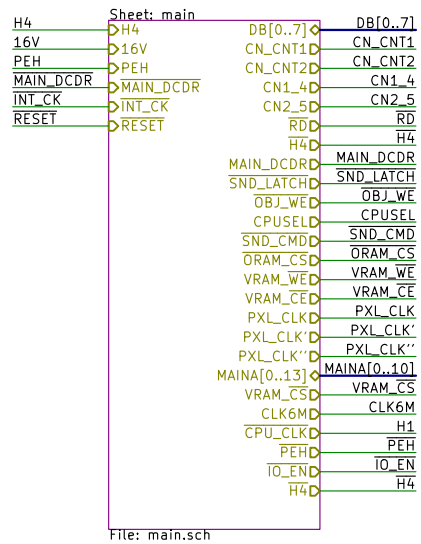

Custom chip 502: double line buffer controller



<https://paypal.me/topapate>
<https://patreon.com/topapate>
 Esperanza D. Triana
 Ping Pong
JOTEGO
 Sheet: /
 File: pingpong.sch
Title: Ping Pong
 Size: A4 | Date: 2022-03-28
 KiCad E.D.A. kicad (5.1.12-1-10_14) | Rev: J. Tejada
 Id: 1/11

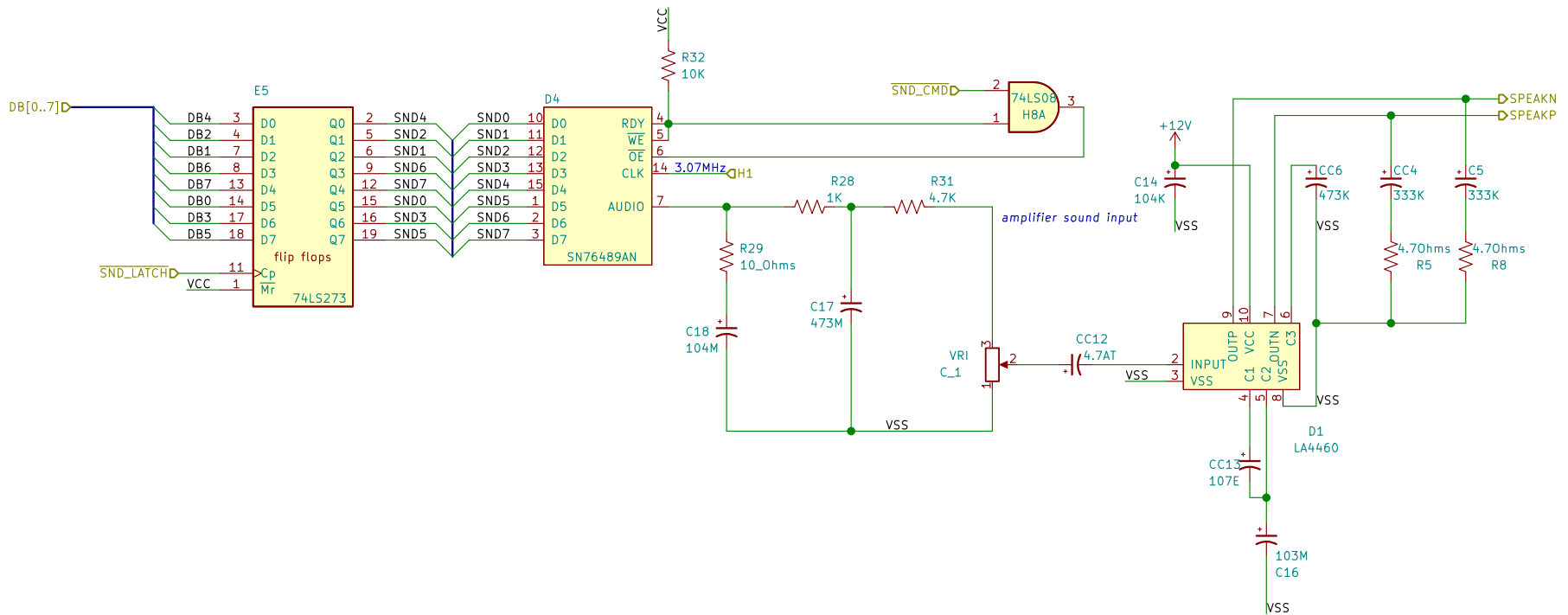

<https://paypal.me/topapate>
<https://patreon.com/topapate>

Esperanza D. Triana
 Ping Pong

JOTEGO

Sheet: /sound/
 File: sound.sch

Title: Sound generator

Size: A4 Date: 2022-03-28
 KiCad E.D.A. kicad (5.1.12-1-10_14)

Rev: J. Tejada
 Id: 2/11



Horizontal Counter

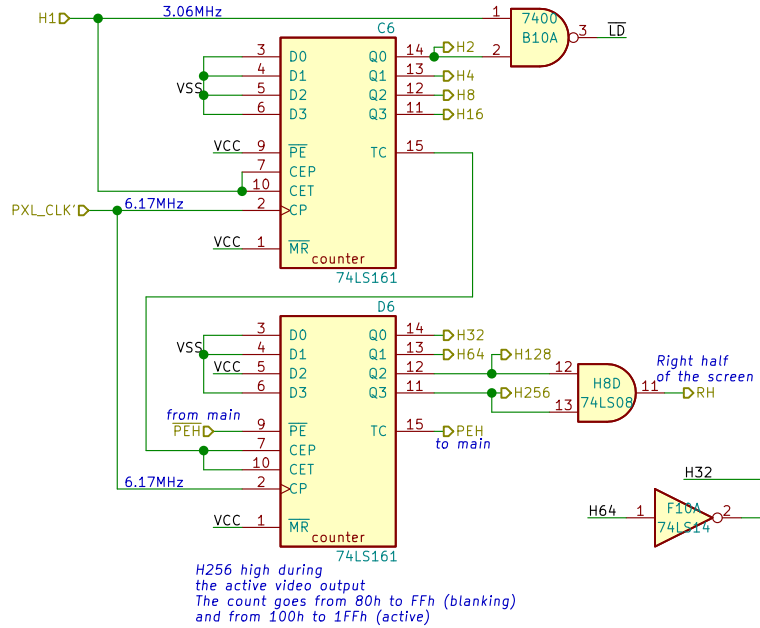

Vertical Counter

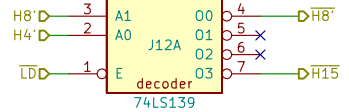
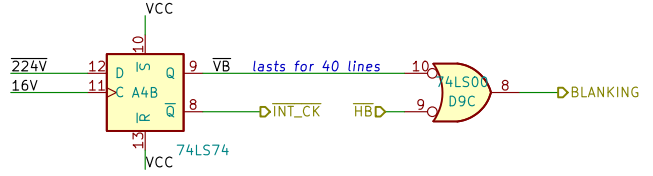
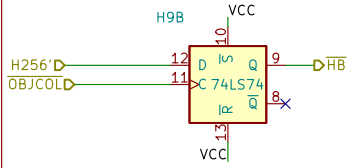
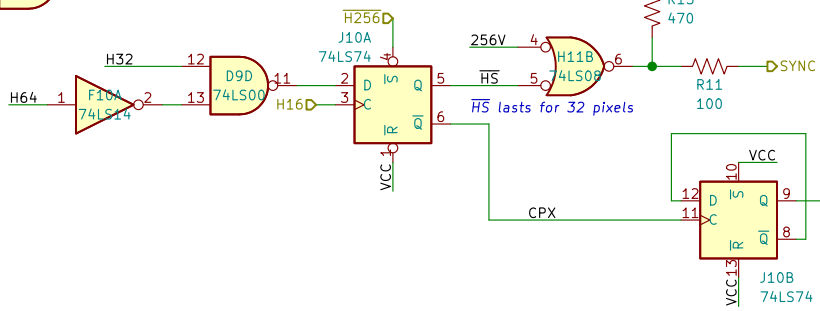
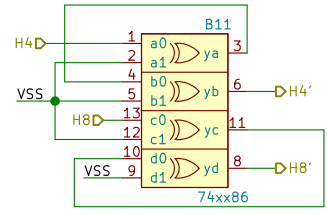
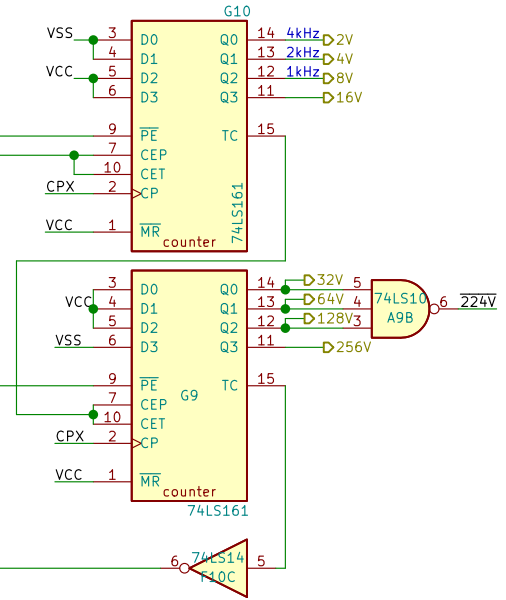

<https://paypal.me/topapate>
<https://patreon.com/topapate>
 Esperanza D. Triana
 Ping Pong



JOTEGO Sheet: /hvcounter/ File: hvcounter.sch	
Title: Horizontal and vertical counters	
Size: A4 KiCad E.D.A. kicad (5.1.12-1-10_14)	Date: 2022-03-28 Rev: J. Tejada Id: 3/11

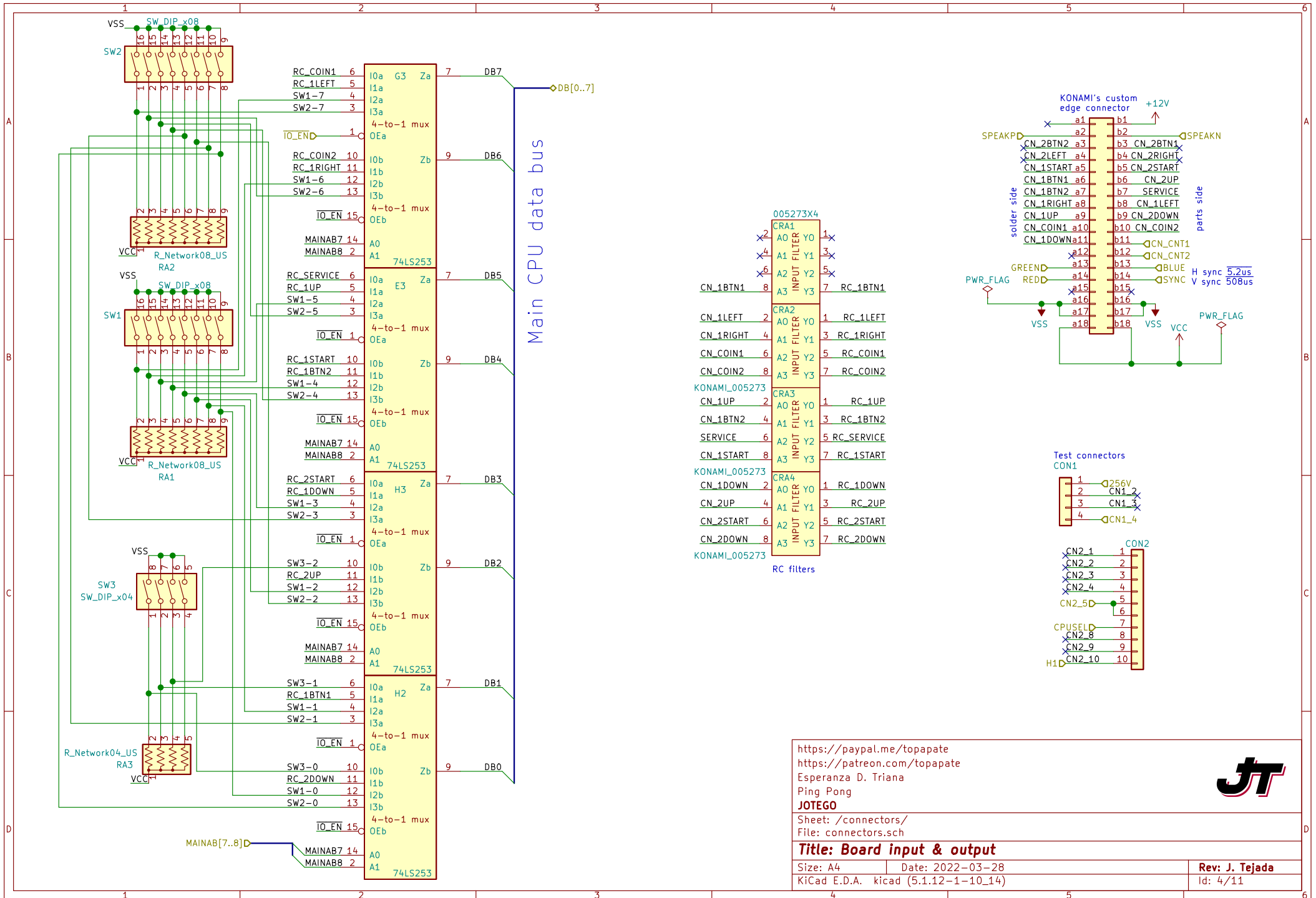

<https://paypal.me/topapate>
<https://patreon.com/topapate>

Esperanza D. Triana
 Ping Pong

JOTEGO

Sheet: /connectors/
 File: connectors.sch

Title: Board input & output

Size: A4 Date: 2022-03-28
 KiCad E.D.A. kicad (5.1.12-1-10_14)

Rev: J. Tejada
 Id: 4/11



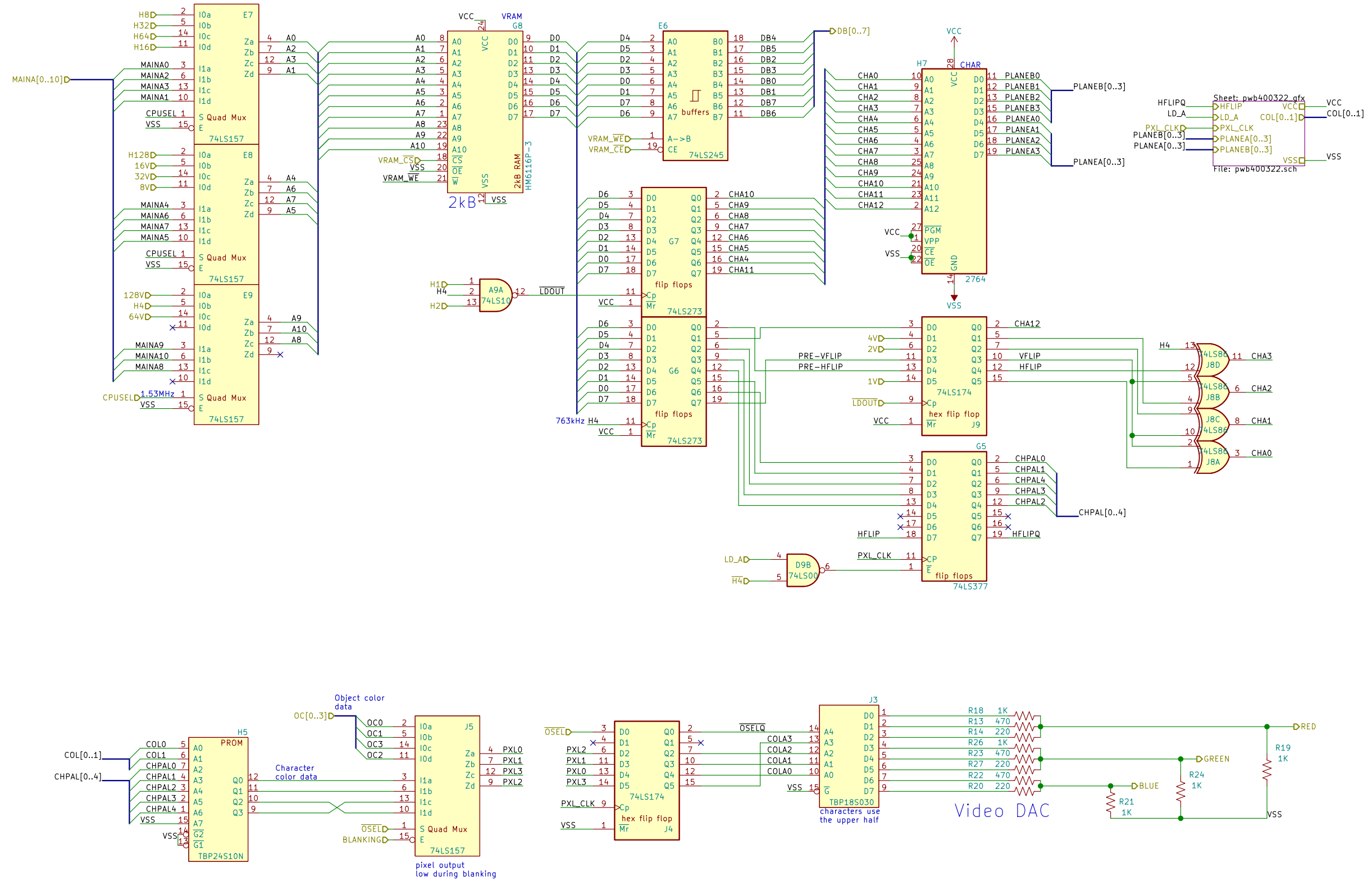

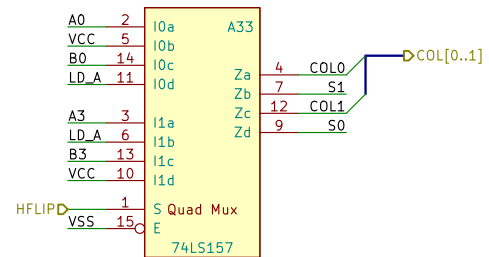
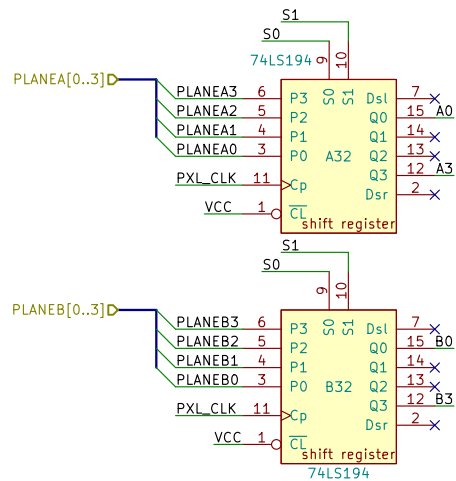
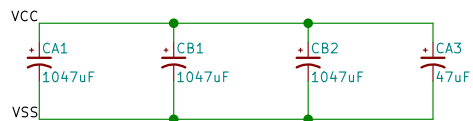
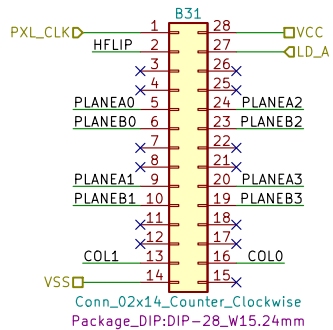

This is a small board soldered to a DIP-28 footprint. It appears twice in the design

PWB-400322

<https://paypal.me/topapate>
<https://patreon.com/topapate>
 Esperanza D. Triana
 Ping Pong
JOTEGO



Sheet: /gfx/pwb400322_gfx/
 File: pwb400322.sch

Title: Pixel shift register

Size: A4 Date: 2022-03-28
 KiCad E.D.A. kicad (5.1.12-1-10_14)

Rev: J. Tejada
 Id: 6/11

MAIN PROGRAM ROM

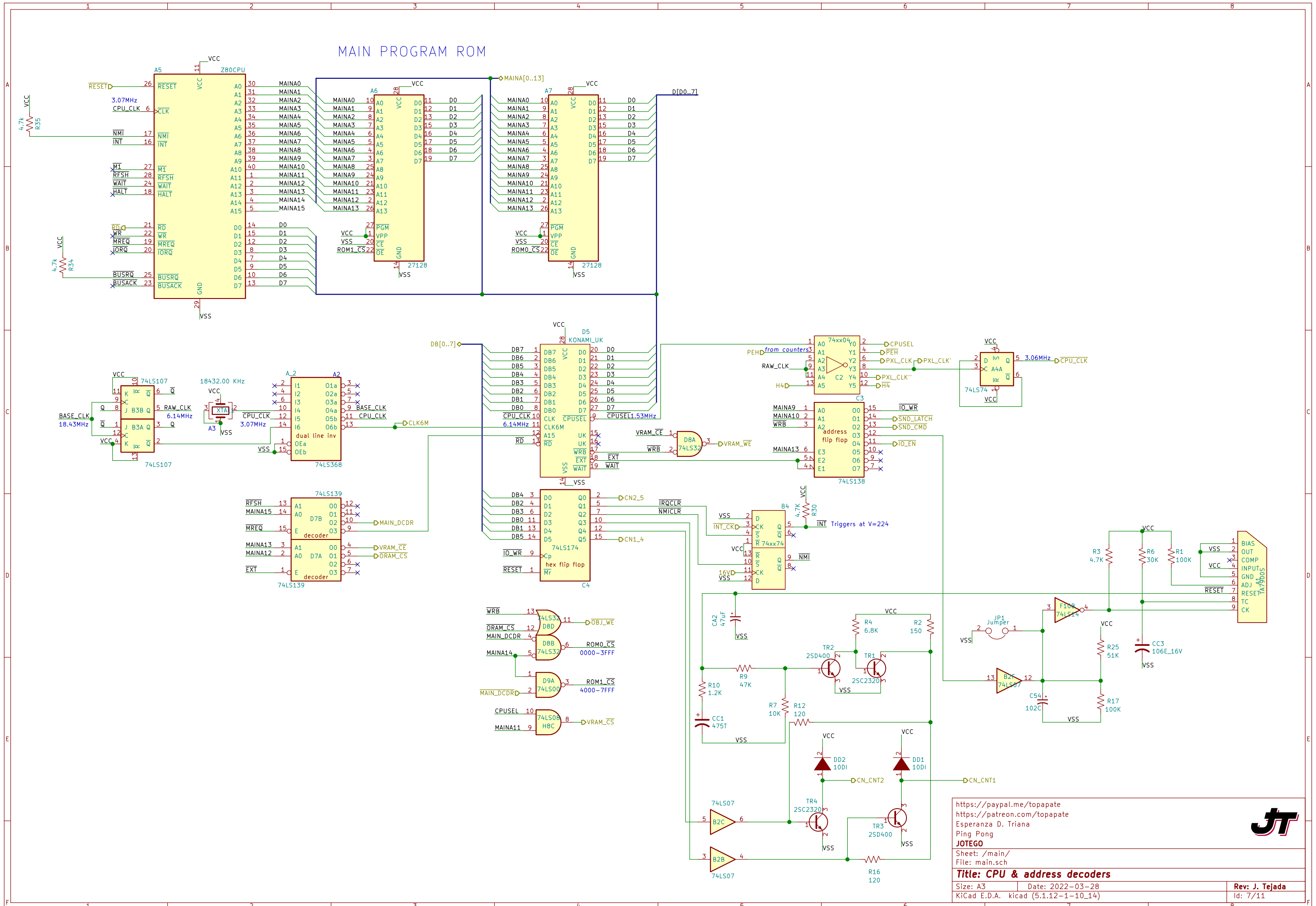

OBJRAM

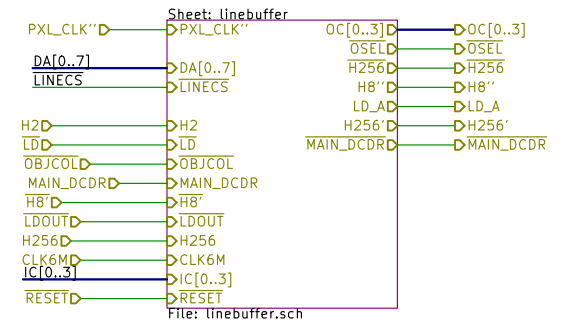
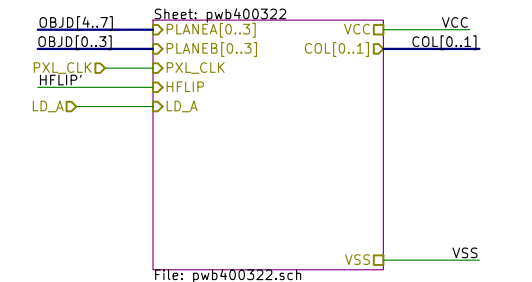
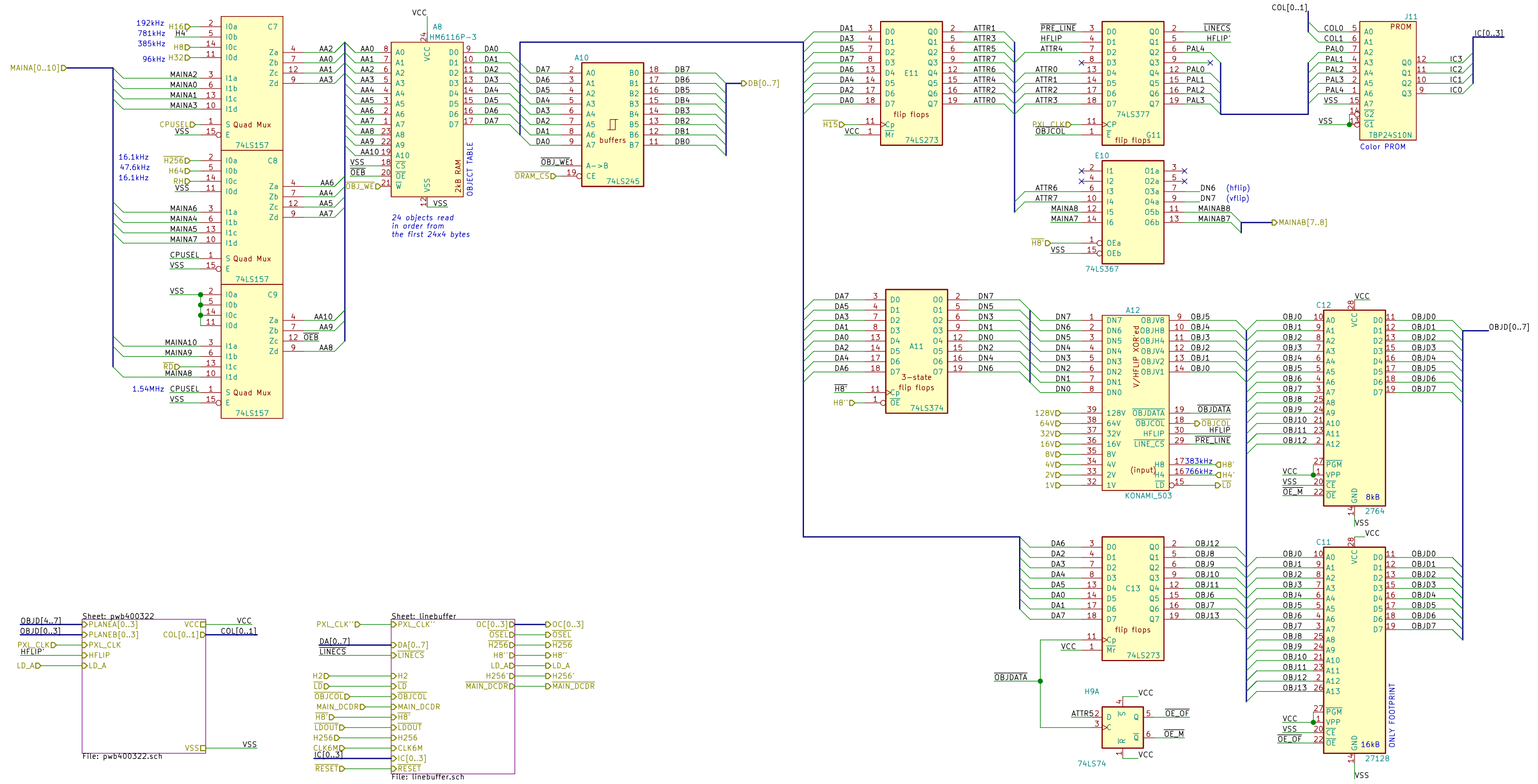

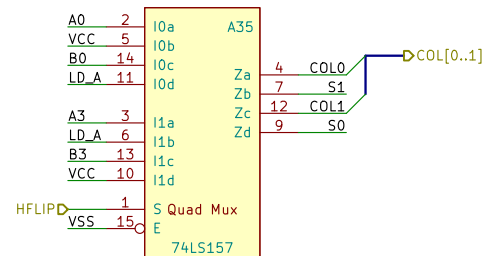
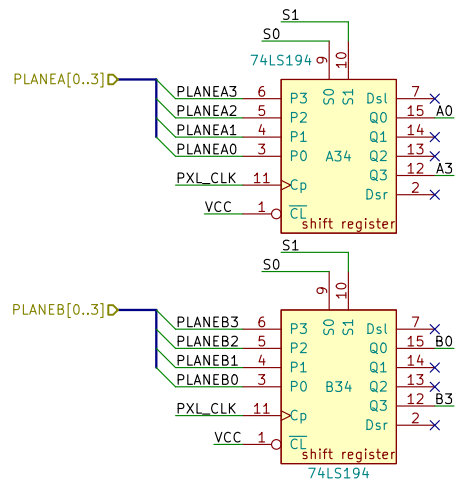
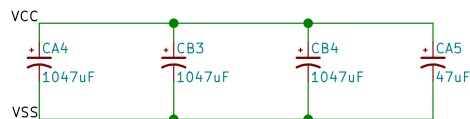
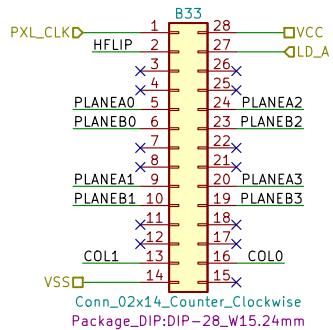

This is a small board soldered to a DIP-28 footprint. It appears twice in the design

PWB-400322

<https://paypal.me/topapate>
<https://patreon.com/topapate>

Esperanza D. Triana
Ping Pong

JOTEGO

Sheet: /object/pwb400322/
File: pwb400322.sch

Title: Pixel shift register

Size: A4 | Date: 2022-03-28
KiCad E.D.A. kicad (5.1.12-1-10_14)

Rev: J. Tejada
Id: 9/11



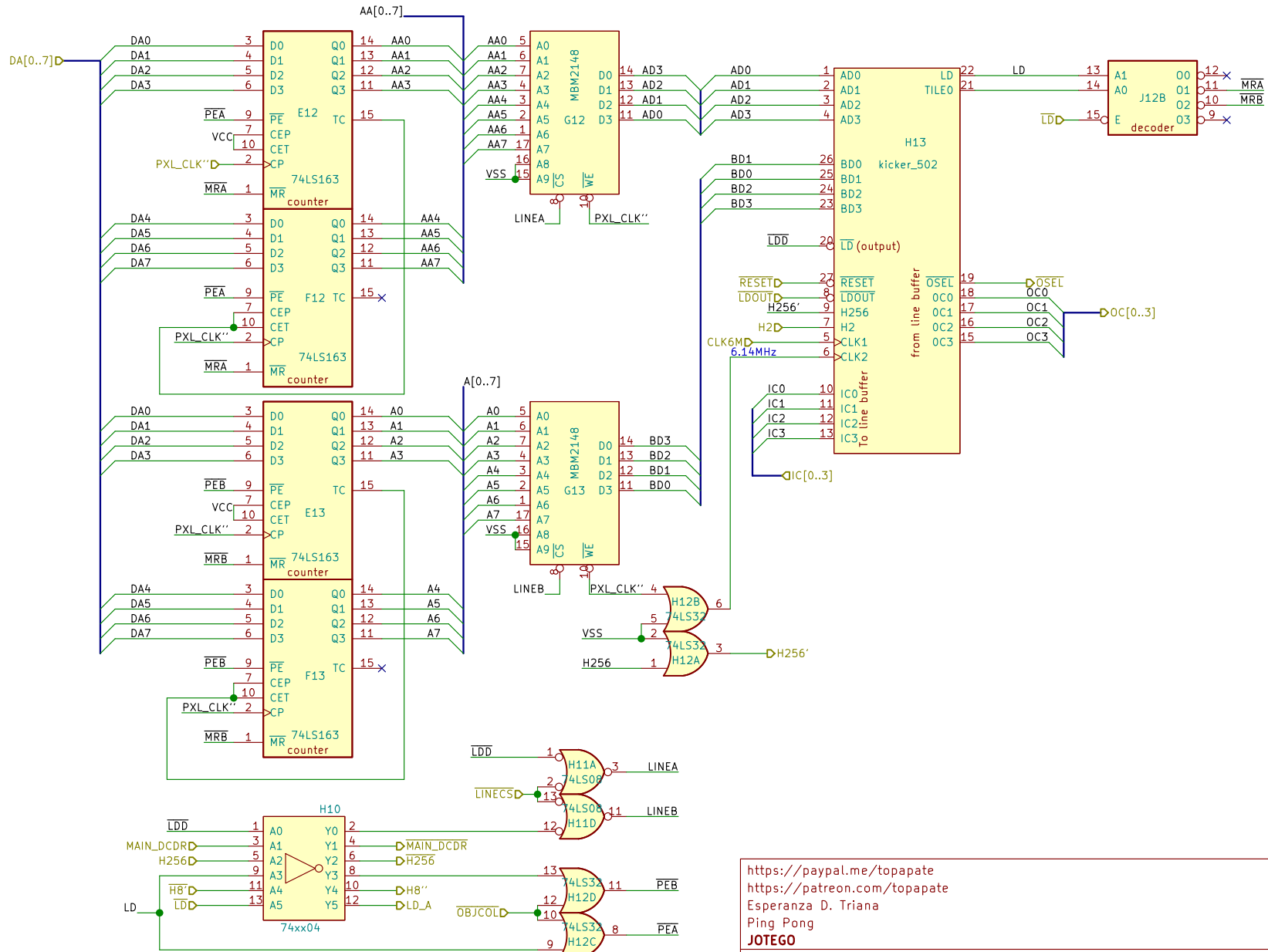

<https://paypal.me/topapate>
<https://patreon.com/topapate>
 Esperanza D. Triana
 Ping Pong
JOTEGO



Sheet: /object/linebuffer/
 File: linebuffer.sch

Title: Double line buffer

Size: A4
 Date: 2022-03-28
 KiCad E.D.A. kicad (5.1.12-1-10_14)

Rev: J. Tejada
 Id: 10/11

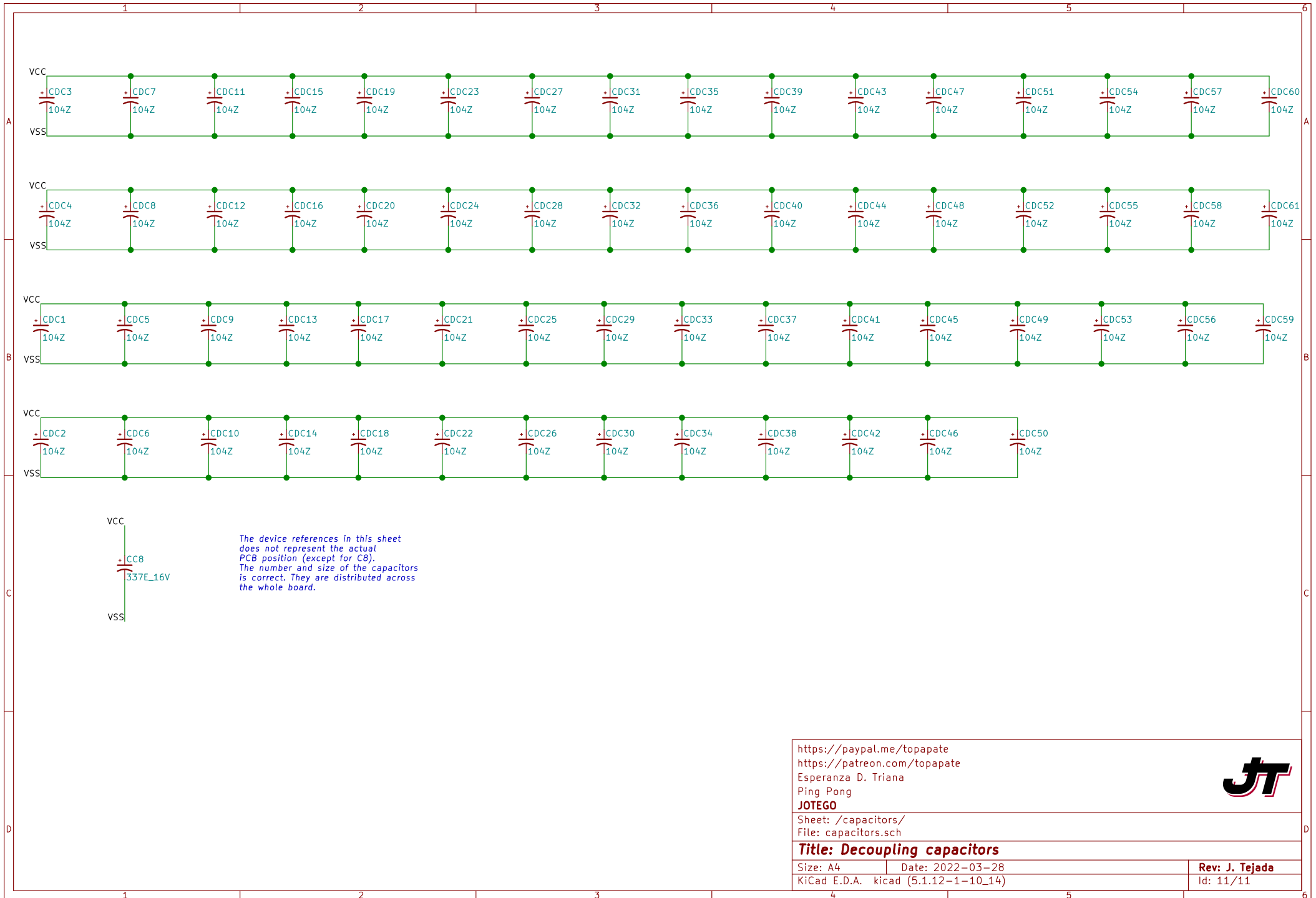

The device references in this sheet does not represent the actual PCB position (except for C8). The number and size of the capacitors is correct. They are distributed across the whole board.

<https://paypal.me/topapate>
<https://patreon.com/topapate>

Esperanza D. Triana
 Ping Pong

JOTEGO

Sheet: /capacitors/
 File: capacitors.sch

Title: Decoupling capacitors

Size: A4 | Date: 2022-03-28
 KiCad E.D.A. kicad (5.1.12-1-10_14)

Rev: J. Tejada
 Id: 11/11

